

# MERKRETE

## Adhesives



## Grouts



## Surface Preparation



## Waterproofing & Crack Isolation

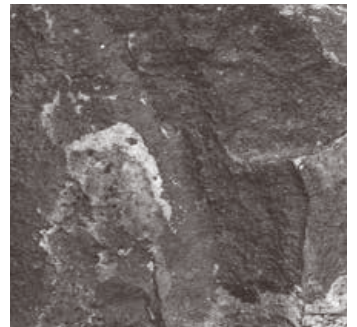
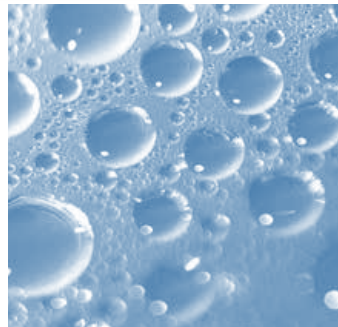

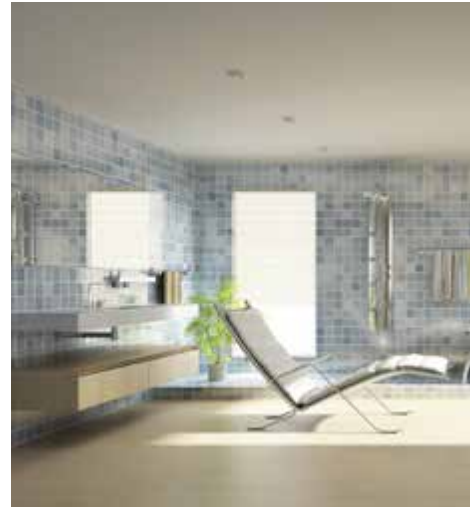

## About Merkrete

Since 1971 Merkrete has successfully provided one billion square feet of tile and stone installation systems. Merkrete has become one of the tile market's most respected brands for innovation, technical knowledge and unique products.

Merkrete tile and stone installation systems exhibit superior innovation and consistently provide the right solution. From underlayment material to grouts, thin sets, waterproofing and crack isolation material—Merkrete offers one of the most

diversified product lines in the industry. Behind every Merkrete product is revolutionary research, groundbreaking development and unsurpassed commitment to quality, customer service and green innovations.



INSTALLATION ADHESIVES.....	4
SPECIALTY ADHESIVES .....	5
SUPERIOR GROUT .....	6
GROUT COVERAGE.....	7
WATERPROOFING MEMBRANES.....	8
CRACK ISOLATION & SOUND CONTROL .....	9
SURFACE PREPARATION .....	10
ADDITIVES & OTHERS .....	11-12
FABRICS.....	12
GROUT PART NUMBERS / UPC CODES.....	13-16







INSTALLATION ADHESIVES		Size	Pack	Part Number	UPC Code
	<b>700 Premium Set</b> is a professional grade mortar for installing ceramic and stone tile and pavers on walls and floors. <b>700 Premium Set</b> can be used for both interior and exterior applications on either residential or light commercial projects. Exceeds ANSI A118.1 for Portland cement mortar.	50 lbs	48/pallet	1698 Gray	716792240165
				1699 White	716792240196
	<b>705 Pro Set Plus</b> is a professional grade mortar for installing porcelain, ceramic tile and stone to walls or floors in either light commercial or residential applications. <b>705 Pro Set Plus</b> exceeds ANSI A118.4 and A118.11 standards.	50 lbs	48/pallet	1701 Gray	716792240134
				1702 White	716792240141
	<b>710 Premium Set Plus</b> is a premium grade polymer modified Portland cement thin set for installing ceramic tile and natural stone. <b>710 Premium Set Plus</b> is recommended for use in the thin set installation method for porcelain, absorptive, semi-vitreous and vitreous tile over properly prepared masonry, concrete and cement backer board. In dry areas, it is suitable for gypsum board.	50 lbs	48/pallet	1704 Gray	716792240172
				1705 White	716792240189
	<b>7D10 Dust Less™</b> Is a premium grade mortar using innovative Dust Less Mortar technology. Improving job site air quality, <b>7D10 Dust Less™</b> Thin Set is suitable for both walls and floors of exterior or interior installations of residential and commercial applications. <b>7D10 Dust Less™</b> Thin Set is ideal for occupied renovation projects and exceeds ANSI A118.4 and A118.11 standards.	50 lbs	48/pallet	1720 Gray	716792240271
				1721 White	716792240288
	<b>720 Marble Pro</b> is a premium grade medium bed thin set for installing large format tile, porcelain gauged and irregular thickness stone tile applications. <b>720 Marble Pro</b> may be used for interior or exterior walls and floors on either residential or commercial projects and exceeds ANSI A118.4 and A118.11 standards.	50 lbs	48/pallet	1707 Gray	716792240059
				1710 White	716792240066
	<b>735 Premium Flex</b> is a superior grade flexible mortar that exceeds ANSI A118.4 and A118.11 standards, offering flexibility, higher strength, plus extended adjustability and open times. 735 Premium Flex was formulated for the interior and exterior installation of ceramic and porcelain tile and stone on both residential and commercial projects.	50 lbs	48/pallet	1711 Gray	716792240080
				1712 White	716792240097
	<b>750 Rapid Set</b> is a rapid-setting mortar offering flexibility and higher strengths while exceeding ANSI A118.4 standards. <b>750 RS</b> Thin Set was formulated for the interior and exterior installation of ceramic and porcelain tile and stone on both residential and commercial projects.	50 lbs	48/pallet	2574 Gray	716792240202
				2575 White	716792240233

MORE  
INFO



SPECIALTY ADHESIVES		Size	Pack	Part Number	UPC Code
 <p><b>808 Specialized Adhesive</b> is a superior grade polymer modified Portland cement quick-setting, flexible thin set mortar for installing ceramic tile and natural stone over sound control membranes like Merkrete Sound Shield PNS 40 or 90, waterproof and crack isolation membranes as well as any other non-absorptive surfaces. It can be used as a thin set mortar for ceramic tile and natural stone for both walls and floors in interior and exterior applications.</p>	50 lbs	48/pallet	1723 Gray	716792972301	
			1724 White	716792972318	
 <p><b>820 Merlite</b> is a superior grade, light weight, flexible thin set mortar with excellent non-s slump and non-sag performance when used for installing ceramic tile and stone on walls or floors. <b>820 Merlite</b> contributes to LEED projects and exceeds ANSI A118.4 and A118.11 standards.</p>	30 lbs	48/pallet	1725 Gray	716792240257	
			1726 White	716792240264	
 <p><b>831 Water Resistant</b> is a special water resistant polymer modified Portland cement thin set for installing ceramic tile and natural stone. <b>831 WR</b> thin set is the perfect solution for tile installations in high moisture areas such as commercial showers, laundry rooms, pool areas, or any areas where repeat and high moisture is prevalent. <b>831 WR</b> Thin Set combines the attributes of a superior thin set adhesive with added water resistant protection. Unlike regular thin set mortars, the water resistant qualities add an increased defense against water infiltration to sub-floors and walls.</p>	50 lbs	48/pallet	1727 Gray	716792972325	
			1728 White	716792972332	
 <p><b>855 XXL: Extra Large Formats - Walls and Floors</b> is a one step polymer modified Portland cement setting adhesive for installing extra large format porcelain, ceramic tile and natural stone on both walls and floors. <b>855 XXL</b>, with its unique Properties, can be used as a thin or medium bed setting adhesive for installing large format, ceramic, porcelain and irregular thickness stone without the need of back buttering the tile.</p>	50 lbs	48/pallet	1729 Gray	716792972349	
			1730 White	716792972356	
 <p><b>856 XLF: Extra Large Formats—Floors XLF</b> is a unique polymer modified Portland cement setting mortar for installing extra large porcelain, ceramic, ultra-thin and stone floor tile. <b>856 XLF</b>, with its exceptional fluid properties, is the ideal adhesive for installing standard to ultra-thin, extra large tile and stone over a variety of substrates including tile over tile applications.</p>	50 lbs	48/pallet	1731 Gray	716792972363	
			1732 White	716792972370	
 <p><b>Integra</b> A non-abrasive all-in-one adhesive and grout for glass tile installations on walls and floors. Integra was developed specifically for the installation of mosaics and glass tile of all shapes and sizes with no concerns about thin set color bleed through because the adhesive and the grout are the same color.</p>	25 lbs	96/pallet	1815-00XXX	See page 14	



SUPERIOR GROUT		Size	Pack	Part Number	UPC Code
 <p><b>Versatile Color Grout</b> A superior multi-purpose polymer-modified Portland cement grout specifically formulated for grouting all types of ceramic and dimensional stone tiles on walls and floors. <b>Versatile</b> is ideal for grouting joint widths less than 1/16" and up to 1/2" wide, and eliminating the need for multiple grout products.</p>	10 lbs	4/case	2769-00XXX	See page 13	
	25 lbs	96/pallet	1889-00XXX	See page 14	
 <p><b>Integra</b> is a non-abrasive all-in-one adhesive and grout for glass tile installations on walls and floors. Integra was developed specifically for the installation of mosaics and glass tile of all shapes and sizes with no concerns about thin set color bleed through because the adhesive and the grout are the same color.</p>	25 lbs	96/pallet	1815-00XXX	See page 14	
 <p><b>ProGrout</b> A premium performance grout, fast setting, polymer-modified, color consistent and efflorescence free specially formulated for grouting all types of ceramic and dimensional stone tiles on walls and floors when grout joint widths are 1/16" and up to 1/2" wide, and eliminating the need for different grout products.</p>	25 lbs	96/pallet	2573-00XXX	See page 14	
 <p><b>Pro Epoxy</b> A three-component, 100% solids epoxy compound developed for use in commercial breweries, dairies, food processing facilities, distilleries, kitchens, bathrooms and other sanitary applications. With an exceptionally high chemical resistance to many acids, alkalis, solvents and household stains, Pro Epoxy is water cleanable before curing, non-flammable and easy to work with.</p>	1 gallon	1 part A 1 part B	1842	716792971779	
	10 lbs of part C	4/case	1843-00XXX	See page 15	
	2 gallons Commercial Kit	2 parts A 2 parts B 20 lbs of part C	1841-00XXX	See page 15	



MORE INFO



## PROGROUT / VERSATILE / INTEGRA

How many square feet can I grout?

TILE SIZE	JOINT WIDTH			
	1/8"	1/4"	3/8"	1/2"
2"x 2"x 1/4"	93	50	36	29
4"x 4"x 3/8"	119	61	43	33
4"x 8"x 3/8"	156	81	56	43
6"x 6"x 3/8"	179	89	61	47
6"x 8"x 3/4"	100	51	35	27
8"x 8"x 3/8"	227	119	81	61
10"x 10"x 3/8"	278	147	100	76
12"x 12"x 3/8"	357	179	119	89
15"x 15"x 3/8"	417	208	147	109
16"x 16"x 3/8"	500	250	167	132
18"x 18"x 3/8"	625	278	192	147
20" x 20" x 3/8"	625	313	208	167

The joint width number represents the square foot coverage per 25 lb bags.



## VERSATILE XF

How many square feet can I grout?

TILE SIZE	JOINT WIDTH		
	1/16"	3/32"	1/8"
1"x 1"x 1/4"	53	37	29
2"x 2"x 1/4"	100	67	53
4"x 2"x 1/4"	125	91	71
4"x 4"x 3/8"	125	91	67
4"x 8"x 3/8"	167	111	91
6"x 6"x 3/8"	200	125	100
8"x 8"x 3/8"	250	167	125
8"x 10"x 1/2"	200	143	111
10"x 10"x 3/8"	333	200	167
12"x 12"x 3/8"	333	250	200
15"x 15"x 3/8"	500	333	250

The joint width number represents the square foot coverage per 25 lb bags.

## INTEGRA THIN SET COVERAGE

RECOMMENDED NOTCH SIZE	
	
1/4" x 1/4" 6 mm x 6 mm	1/4" x 3/8" 6 mm x 10 mm
Ceramics and Mosaics	Quarry Tile, Rough Stone
APPROXIMATE COVERAGES – 25 LBS	
32 – 35 Ft <sup>2</sup> 3.0 m <sup>2</sup> – 3.4 m <sup>2</sup>	27 – 32 Ft <sup>2</sup> 2.5 m <sup>2</sup> – 3.0 m <sup>2</sup>

\* Coverage depends on towel notch size, substrate and job conditions

## PRO EPOXY

How many square feet can I grout?

### PRO EPOXY GROUT COVERAGE CHART

#### SQUARE FEET PER GALLON

MOSAICS	JOINT WIDTHS		
	1/8"	1/4"	3/8"
1" x 1" x 3/16"	0.19	0.19	0.35
2" x 2" x 1/4"	0.14	0.14	0.27
4" x 4" x 1/4"	0.07	0.07	0.14

#### WALL TILE

#### JOINT WIDTHS

	1/8"	1/4"	3/8"
4-1/4" x 4-1/4" x 5/16"	92	48	32
6" x 6" x 1/4"	160	82	58

#### FLOOR TILE

#### JOINT WIDTHS

	1/8"	1/4"	3/8"
4' x 8" x 1/2"	72	36	26
6" x 6" x 3/8"	106	58	40
6" x 6" x 1/2"	80	42	28
8" x 8" x 3/8"	142	72	58
12" x 12" x 3/8"	210	106	72
12" x 12" x 1/2"	156	80	54
12" x 12" x 5/16"	84	42	28
13" x 13" x 3/8"	228	116	78
16" x 16" x 3/8"	280	142	96
18" x 18" x 3/8"	312	156	106
20" x 20" x 3/8"	344	176	118

### PRO EPOXY SETTING MATERIAL COVERAGE CHART

#### SQUARE FEET PER GALLON

Trowel Size	3/16" x 1/4" V-Notch	1/4" x 1/4" Square Notch
Pro Epoxy per Gal.	36	22





The values obtained from the chart are based on an empty grout joint and it does not account for setting material left in the joint or waste. Actual grout usage may vary due to installation techniques and different types of tile surfaces used on the jobsite.



## GROUT CALCULATOR

[http://www.merkrete.com/grout\\_calculator.shtml](http://www.merkrete.com/grout_calculator.shtml)







WATERPROOFING MEMBRANES		Size	Pack	Part Number	UPC Code	Coverage
	<b>Hydro Guard 1</b> is a single component waterproofing system that does not require the use of fabric reinforcement. It is the economic waterproofing solution for residential and light commercial demands.	1 gallon	144/pallet	1802	716792970109	50 sq ft
		3 1/2 gallon	48/pallet	2591	716792969622	175 sq ft
	<b>Hydro Guard 2000</b> is a commercial grade heavy-duty membrane and fabric waterproofing system that protects over time under the most stressful situations. <b>Hydro Guard 2000</b> is used in major hotels, casinos, athletic venues, steam rooms and commercial buildings throughout the U.S.	2 gallon	72/pallet	1797	716792969974	100 sq ft
		5 gallon	36/pallet	1798	716792970079	250 sq ft
	<b>Hydro Guard SP-1</b> is a fast-drying single component waterproofing system that offers LEED/Green and time saving attributes. When time is critical, <b>Hydro Guard SP-1</b> is the answer.	1 gallon	144/pallet	1806	716792970123	50 sq ft
		5 gallon	36/pallet	1807	716792970147	250 sq ft
	<b>BFP</b> waterproofing membrane system is used for severe exposures and high traffic installations. Durable and long lasting, this membrane system is designed specifically for heavy duty applications like high rise buildings, malls and exterior decks to provide waterproofing and crack resistance for thin set installed ceramic, terrazzo, quarry and stone tile.	BFP Latex 5 gallon	36/pallet	1736	716792970154	125 sq ft
		BFP Filler 40 lb	48/pallet	1737	716792970161	
		BFP Emulsion 5 gallon	36/pallet	1738	716792970000	200 sq ft







MORE  
INFO





CRACK ISOLATION & SOUND CONTROL		Size	Pack	Part Number	UPC Code	Coverage
	<b>Fracture Guard 7000</b> is the first liquid applied membrane to provide crack isolation up to 3/8". It offers maximum protection for your tile and stone installation by inhibiting the transfer of cracks from the substrate to the ceramic, porcelain or stone tile. It is ultra-flexible with an elongation over 1000%.	3 1/2 gallon	48/pallet	3139	71679223992	280 sq ft
	<b>Fracture Guard Fast Drying</b> is a low VOC, fast drying crack isolation membrane for production driven and same day tile installations. <b>Fracture Guard FD</b> provides a thin protection layer to inhibit substrate crack transfers up to 1/8". Because <b>Fracture Guard FD</b> is a liquid applied membrane it conforms to any shape or pattern, thus allowing endless architectural designs. Used on both residential and commercial interior and exterior applications, <b>Fracture Guard FD</b> offers essential valued protection.	3 1/2 gallon	48/pallet	1779	716792970055	280 sq ft
	<b>Sound Shield PNS 40 and PNS 90</b> An efficient peel and stick, rubberized asphalt base sheet membrane that adheres directly to any sound substrate that is normally acceptable to tile applications. It is used to protect tile installations against potential and severe substrate crack transfers. Sound Shield PNS 40 inhibits the transfer of substrate cracks up to 1/2" and is the best protection when installing natural travertine or soft stone tiles. Sound Shield PNS 90 inhibits the transfer of substrate cracks up to 3/8" and is the best protection when installing natural travertine or soft stone tiles.	PNS 40 3'x75"	20 rolls per pallet	1865	716792970178	225 sq ft/roll
		PNS 90 3'x33.3"	20 rolls per pallet	1866	716792970185	100 sq ft/roll





SURFACE PREPARATION		Size	Pack	Part Number	UPC Code	Coverage	
	<b>Pro Patch Plus</b> A quick-setting polymer modified Portland cement based skim coating compound suitable for coating unfinished, or rough concrete. Ideal for filling voids, holes and cracks in plywood and concrete substrates, <b>Pro PatchPlus</b> is specifically formulated to smooth and finish substrates prior to the installation of resilient flooring, carpet, ceramic and stone tiles.	25 lbs	96/pallet	2528	716792240363	thickness	sq ft
						1/8"	25
	<b>Underlay C</b> Developed to provide a solid foundation substrate for the installation of vinyl, resilient tile, carpet, ceramic and stone tile. Also appropriate for the repair of concrete surfaces, Underlay C is ideal for achieving a slope base foundation for any floor requiring a slope for drainage purposes.	50 lbs	48/pallet	1879	716792970215	thickness	sq ft
						1/8"	50
	<b>Underlay RS</b> is a rapid-setting, troweled polymer modified underlayment designed to provide a suitable surface for floor coverings such as vinyl, resilient tile, carpet, ceramic and stone tile. Ideal for achieving a slope base foundation for any floor requiring a slope, <b>Underlay RS</b> includes antimicrobials to inhibit the growth of mold and mildew.	50 lbs	48/pallet	1885	716792970253	thickness	sq ft
						1/8"	50
	<b>Underlay Self Leveling</b> is an underlayment designed for rapid leveling of interior substrates that have been coated with <b>Underlay SLU Primer</b> . A high durability, Portland cement based, pourable, pumpable, free-flowing underlayment, <b>Underlay SLU</b> is acceptable for the installation of all floor coverings, and is ideal for new construction or remodeling of either residential or commercial applications.	50 lbs	48/pallet	1886	716792970260	thickness	sq ft
						1/8"	50
	<b>Underlay Self Leveling Gold</b> is a premium fast setting, high compression strength, pourable, pumpable and free flowing underlayment for leveling of interior floor substrates. <b>SLU GOLD</b> can be poured from 1/8" to 4" thickness in one pour. <b>Underlay SLU GOLD</b> is specifically formulated to be smooth and level substrates with excellent durability, and is acceptable for the installation of all floor coverings, and especially for leveling for large format tile installations. <b>SLU GOLD</b> is ideal for new construction and remodeling projects, in both residential and commercial applications.	50 lbs	48/pallet	1887	716792972387	thickness	sq ft
						1/8"	50
						1/4"	25

MORE INFO



ADDITIVES & OTHERS		Size	Pack	Part Number
	BURST Add-A-Pak is a powerful additive used to give Portland cement products a BURST of accelerant for faster set times. It can be used to help speed up work times in most any portland cement mortar such as mud beds, masonry mortars, underlayments, thin sets and grouts.	1 lb	30/case	2521
	150 Latex Admixture is a compounded and stabilized latex additive used to improve bond strength, water resistance, compressive strength and other physical properties of cement/ sand mixes as well as grouts.	1 gallon	NA	1694
		5 gallons		1696
	442 Tuff Flex is a compounded and stabilized latex emulsion for use with 700 Premium Set (or a non-modified thin set mortar). 700 Premium Set (or a non-modified thin set) with the addition of 442 Tuff Flex is notched troweled to form a thin mortar bed for the installation of porcelain, granite, quarry tile, glass mosaic, dimensional stone and other hard to bond tiles. When cured, these mortars display excellent physical properties in adhesion, resiliency, water and weather resistance, and exceed ANSI A-118.4 requirements.	5 gallon	NA	1878
	Revive is a pigmented water-based urethane acrylic grout stain and sealer.	8 oz	NA	1862-00XXX
	Colored Caulking is an exceptional, one part siliconized acrylic based caulking compound that is mold and mildew resistant. Special chemicals are added while manufacturing to greatly improve the workability, curing, flexural strength and resistance to a broad spectrum of fungal, algae and bacterial degradation. Colored Caulking is available in a sanded and smooth (non sanded) formulation color coordinated to all of Merkrete Color Grout colors.	10.5 oz	6/case	1748-00XXX SANDED 1749-00XXX SMOOTH  See page 13
	Grout Sealer is a penetrating silicone sealer for new or old portland cement grout. It is a water-based, silicone resin designed to protect grout surfaces from stains and water. It is also recommended for concrete, porous stone and masonry surfaces. It quickly penetrates, producing a sub-surface hydrophobic reaction below the surface. It does not change most surfaces, leaving a natural look.	1 quart	NA	1794
		1 gallon		1795
	Self Leveling Primer is an uniquely formulated emulsion that must be applied to all substrates prior to the application of Underlayment Self Leveling.	1 gallon	NA	1883



ADDITIVES & OTHERS		Size	Pack	Part Number
	<p>626 Primer is a thin section two-component primer; composed of a modified elastomeric copolymer and cementitious filler powder. 626 Primer provides a water resistant bond coat primer that adheres to most difficult to bond substrates. The primer is trowel applied and can be installed on practically any form or irregular shape.</p>	626 Primer Filler 40#	NA	1831
		626 Primer 5 gallon	NA	1832
		626 Primer 1 gallon kit	NA	1833
	<p>Prep Seal is a water-based bonding agent formulated to increase bonds between liquid membrane layers. Prep Seal bonding agent provides a water resistant bond coat that assists in adhering Merkrete liquid membrane coats and thin sets. The bonding agent is brush, roller or trowel applied and can be installed on practically any form or irregular shape.</p>	5 gallon	NA	1825
	<p>Prep Seal PNS is a water-based latex primer that is applied to concrete substrates prior to the application of Merkrete Peel-N-Stick membranes.</p>	1 gallon	NA	1826

FABRICS		Contains	Part Number
	Type 2 – 1300 sq ft	1 roll 36" x 405' 1 roll 8" x 165'	1761
	Type 2 – 280 sq ft	1 roll 36" x 75' 1 roll 8" x 90'	1762
	Type 2 – 36" x 405'	1 roll 36" x 405'	1766
	Type 2 – 8" x 165'	1 roll 8" x 165'	1769
	Type 2 – roll 8" x 90'	1 roll 8" x 90'	1770
	Type 3 – Burlap 10"	300 linear ft roll	1771
	Type 3 – Burlap 40"	1,000 linear ft roll	1772



			ME COLOR CAULK SANDED		ME COLOR CAULK SMOOTH	
COLOR	PART NUMBER	UPC CODE	PART NUMBER	UPC CODE		
00011 SNOW WHITE	1748-00011	716792130015	1749-00011	716792140014		
00012 NAVAJO WHITE	1748-00012	716792130039	1749-00012	716792140038		
00015 SWISS COFFEE	1748-00015	716792130084	1749-00015	716792140083		
00017 BONE	1748-00017	716792130121	1749-00017	716792140120		
00018 CREAM	1748-00018	716792130145	1749-00018	716792140144		
00021 CANVAS	1748-00021	716792130169	1749-00021	716792140168		
00023 LATTE	1748-00023	716792130176	1749-00023	716792140175		
00024 CHAMOIS	1748-00024	716792130183	1749-00024	716792140182		
00025 TUMBLEWEED	1748-00025	716792130190	1749-00025	716792140199		
00030 SILVER	1748-00030	716792130206	1749-00030	716792140205		
00032 LIGHT TAUPE	1748-00032	716792130213	1749-00032	716792140212		
00034 RIVER ROCK	1748-00034	716792130220	1749-00034	716792140229		
00035 NATURAL GRAY	1748-00035	716792130237	1749-00035	716792140236		
00038 GRAY	1748-00038	716792130244	1749-00038	716792140243		
00057 HARVEST	1748-00057	716792130305	1749-00057	716792140304		
00063 CARMEL	1748-00063	716792130343	1749-00063	716792140342		
00071 SANDSTONE*	1748-00071	716792130350	1749-00071	716792140359		
00134 NEW ADOBE	1748-00134	716792130053	1749-00134	716792140052		
00137 AZTEC	1748-00137	716792130060	1749-00137	716792140069		
00145 MOCHA*	1748-00145	716792130077	1749-00145	716792140076		
00150 SANTA FE*	1748-00150	716792130091	1749-00150	716792140090		
00153 BUCKSKIN*	1748-00153	716792130107	1749-00153	716792140106		
00162 TRUE TAUPE	1748-00162	716792130114	1749-00162	716792140113		
00178 COCO	1748-00178	716792130138	1749-00178	716792140137		
00191 TERRACOTTA*	1748-00191	716792130152	1749-00191	716792140151		
00525 BLACK SAPPHIRE	1748-00525	716792130282	1749-00525	716792140281		
00568 TANZANITE*	1748-00568	716792130299	1749-00568	716792140298		
00572 NEW DENIM*	1748-00572	716792130312	1749-00572	716792140311		
00583 ANCIENT JADE*	1748-00583	716792130329	1749-00583	716792140328		
00587 CARIBBEAN SEA*	1748-00587	716792130336	1749-00587	716792140335		

\*Premium Colors



**ME PROGROUT 25#**

COLOR	PART NUMBER	UPC
00011 SNOW WHITE	2573-00011	716792969639
00012 NAVAJO WHITE	2573-00012	716792969646
00017 BONE	2573-00017	716792969691
00018 CREAM	2573-00018	716792969714
00021 CANVAS	2573-00021	716792969622
00023 LATTE	2573-00023	716792969738
00024 CHAMOIS	2573-00024	716792969745
00025 TUMBLEWEED	2573-00025	716792969752
00030 SILVER	2573-00030	716792969615
00035 NATURAL GRAY	2573-00035	716792969769
00038 GRAY	2573-00038	716792969776
00057 HARVEST	2573-00057	716792969790
00071 SANDSTONE*	2573-00071	716792969813
00137 AZTEC	2573-00137	716792969653
00145 MOCHA*	2573-00145	716792969660
00150 SANTA FE*	2573-00150	716792969677
00153 BUCKSIN*	2573-00153	716792969684
00178 COCO	2573-00178	716792969707
00191TERRACOTTA*	2573-00191	716792969721
00525 BLACK SAPPHIRE	2573-00525	716792969783

\*Premium Colors

**ME VERSATILE XF 10#**

COLOR	PART NUMBER	UPC
00011 SNOW WHITE	3040-00011	716792969271
00012 NAVAJO WHITE	3040-00012	716792969288
00015 SWISS COFFEE	3040-00015	716792969295
00017 BONE	3040-00017	716792969301
00018 CREAM	3040-00018	716792969318
00021 CANVAS	3040-00021	716792969325
00023 LATTE	3040-00023	716792969332
00024 CHAMOIS	3040-00024	716792969349
00025 TUMBLEWEED	3040-00025	716792969356
00030 SILVER	3040-00030	716792969363
00032 LIGHT TAUPE	3040-00032	716792969370
00034 RIVER ROCK	3040-00034	716792969387
00035 NATURAL GRAY	3040-00035	716792969394
00038 GRAY	3040-00038	716792969400
00057 HARVEST	3040-00057	716792969448
00063 CARMEL	3040-00063	716792969455
00071 SANDSTONE*	3040-00071	716792969462
00134 NEW ADOBE	3040-00134	716792969493
00137 AZTEC	3040-00137	716792969509
00145 MOCHA*	3040-00145	716792969516
00150 SANTA FE*	3040-00150	716792969523
00153 BUCKSKIN*	3040-00153	716792969530
00162 TRUE TAUPE	3040-00162	716792969547
00178 COCO	3040-00178	716792969554
00191 TERRACOTTA*	3040-00191	716792969561
00525 BLACK SAPPHIRE	3040-00525	716792969578
00568 TANZANITE*	3040-00568	716792969585
00572 NEW DENIM*	3040-00572	716792969592
00583 ANCIENT JADE*	3040-00583	716792969608
00587 CARIBBEAN SEA*	3040-00587	716792969615

\*Premium Colors

**ME INTEGRA 25#**

COLORS	PART NUMBER	UPC CODE
00011 SNOW WHITE	1815-00011	716792970314
00015 SWISS COFFEE	1815-00015	716792970338
00017 BONE	1815-00017	716792970345
00025 TUMBLEWEED	1815-00025	716792970390
00030 SILVER	1815-00030	716792970406
00038 GRAY	1815-00038	716792970444
00153 BUCKSIN*	1815-00153	716792970482
00525 BLACK SAPPHIRE	1815-00525	716792970611

\*Premium Colors



ME PRO EPOXY PART C			ME PRO EPOXY COMMERCIAL KIT	
COLOR	PART NUMBER	UPC CODE	PART NUMBER	UPC CODE
00012 NAVAJO WHITE	1843-00012	716792971786	1841-00012	716792972004
00017 BONE	1843-00017	716792971793	1841-00017	716792972011
00018 CREAM	1843-00018	716792971809	1841-00018	716792972028
00021 CANVAS	1843-00021	716792971816	1841-00021	716792972035
00024 CHAMOIS	1843-00024	716792971823	1841-00024	716792972042
00025 TUMBLEWEED	1843-00025	716792971830	1841-00025	716792972059
00030 SILVER	1843-00030	716792971847	1841-00030	716792972066
00032 LIGHT TAUPE	1843-00032	716792971854	1841-00032	716792972073
00034 RIVER ROCK	1843-00034	716792971861	1841-00034	716792972080
00035 NATURAL GRAY	1843-00035	716792971878	1841-00035	716792972097
00038 GRAY	1843-00038	716792971885	1841-00038	716792972103
00063 CARMEL	1843-00063	716792971892	1841-00063	716792972110
00071 SANDSTONE*	1843-00071	716792971908	1841-00071	716792972127
00145 MOCHA*	1843-00145	716792971915	1841-00145	716792972134
00150 SANTA FE*	1843-00150	716792971922	1841-00150	716792972141
00153 BUCKSKIN*	1843-00153	716792971939	1841-00153	716792972158
00162 TRUE TAUPE	1843-00162	716792971946	1841-00162	716792972165
00178 COCO	1843-00178	716792971953	1841-00178	716792972172
00191 TERRACOTTA*	1843-00191	716792971960	1841-00191	716792972189
00525 BLACK SAPPHIRE	1843-00525	716792971977	1841-00525	716792972196
00568 TANZANITE*	1843-00568	716792971984	1841-00568	716792972202
00583 ANCIENT JADE*	1843-00583	716792971991	1841-00583	716792972219

\*Premium Colors



COLOR	ME VERSATILE 10#		ME VERSATILE 25#	
	PART NUMBER	UPC	PART NUMBER	UPC
00011 SNOW WHITE	2769-00011	716792971021	1889-00011	716792970673
00012 NAVAJO WHITE	2769-00012	716792971038	1889-00012	716792970680
00015 SWISS COFFEE	2769-00015	716792971045	1889-00015	716792970697
00017 BONE	2769-00017	716792971052	1889-00017	716792970703
00018 CREAM	2769-00018	716792971069	1889-00018	716792970710
00021 CANVAS	2769-00021	716792971076	1889-00021	716792970727
00023 LATTE	2769-00023	716792971083	1889-00023	716792970734
00024 CHAMOIS	2769-00024	716792971090	1889-00024	716792970741
00025 TUMBLEWEED	2769-00025	716792971106	1889-00025	716792970758
00030 SILVER	2769-00030	716792971113	1889-00030	716792970765
00032 LIGHT TAUPE	2769-00032	716792971120	1889-00032	716792970772
00034 RIVER ROCK	2769-00034	716792971137	1889-00034	716792970789
00035 NATURAL GRAY	2769-00035	716792971144	1889-00035	716792970796
00038 GRAY	2769-00038	716792971151	1889-00038	716792970802
00057 HARVEST	2769-00057	716792971199	1889-00057	716792970840
00063 CARMEL	2769-00063	716792971205	1889-00063	716792970857
00071 SANDSTONE*	2769-00071	716792971212	1889-00071	716792970864
00134 NEW ADOBE	2769-00134	716792971243	1889-00134	716792970895
00137 AZTEC	2769-00137	716792971250	1889-00137	716792970901
00145 MOCHA*	2769-00145	716792971267	1889-00145	716792970918
00150 SANTA FE*	2769-00150	716792971274	1889-00150	716792970925
00153 BUCKSKIN*	2769-00153	716792971281	1889-00153	716792970932
00162 TRUE TAUPE	2769-00162	716792971298	1889-00162	716792970949
00178 COCO	2769-00178	716792971304	1889-00178	716792970956
00191 TERRACOTTA*	2769-00191	716792971311	1889-00191	716792970963
00525 BLACK SAPPHIRE	2769-00525	716792971328	1889-00525	716792970970
00568 TANZANITE*	2769-00568	716792971335	1889-00568	716792970987
00572 NEW DENIM*	2769-00572	716792971342	1889-00572	716792970994
00583 ANCIENT JADE*	2769-00583	716792971359	1889-00583	716792971007
00587 CARIBBEAN SEA*	2769-00587	716792971366	1889-00587	716792971014

\*Premium Colors



www.merkrete.com

**Corporate Office**

Parex USA, Inc.  
 4125 E. La Palma Ave., Suite 250  
 Anaheim, CA 92807  
 (866) 516-0061  
 Tech Support: (800) 226-2424

**Facilities**

French Camp, CA  
 North Hollywood, CA  
 Riverside, CA  
 San Diego, CA  
 Colorado Springs, CO

Haines City, FL  
 Duluth, GA  
 Redan, GA  
 Albuquerque, NM  
 Allentown, PA  
 San Antonio, TX



**PAREX USA SUSTAINABILITY**